

There is a mobile ball inside the check valve. Rolling with the fluid, this constantly moving ball with special surface cover cleans itself and prevents dirt accumulation in its periphery and ensures operation of check valve without jamming.

Scope of application;

- Fluids with high viscosity including,
- Chemical fluids,
- Process waste water and muddy water,
- Cesspool.

Connection Diameter ;

DN25-DN65

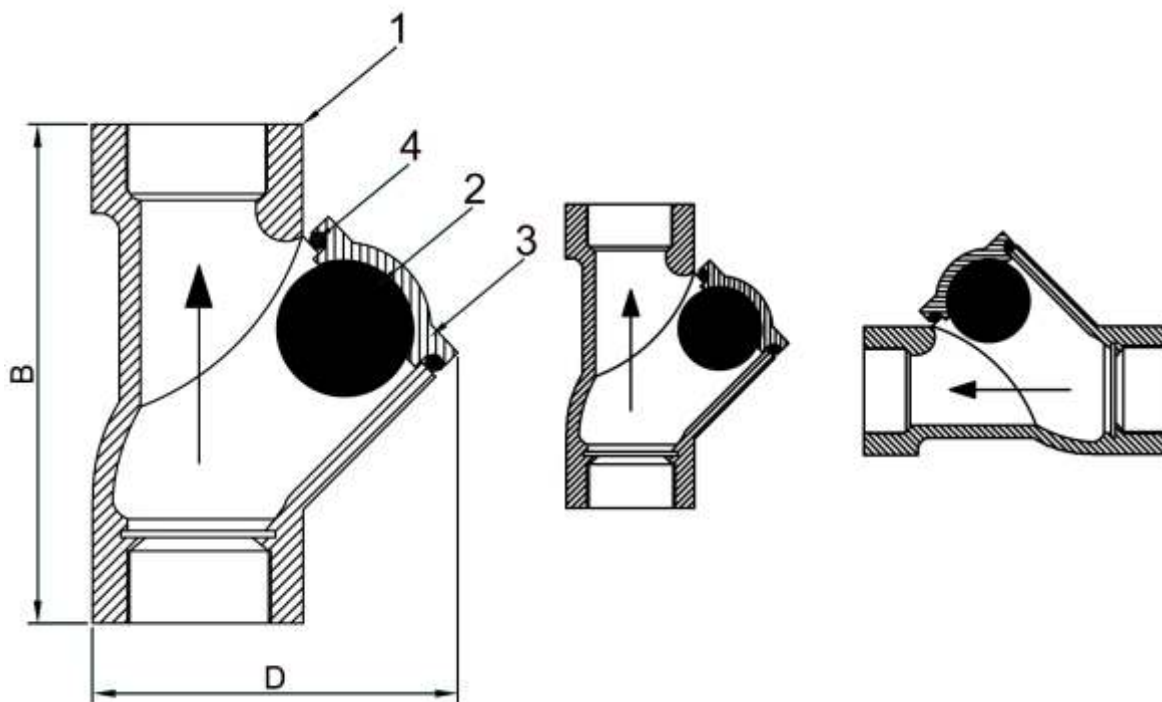

Standart Materials

1	Housing	Pig casting
2	Ball	Hardened epoxy resin
3	Maintenance lid	Pig casting
4	O-ring	EPDM rubber

Connection Diameter

Dimensions

DN	Inch	B	D
25	1"	38	22
32	1 1/4"	48	32
40	1 1/2"	63	40
50	2"	74	54
65	2 1/2"	90	70