

**Description:** Resilient Seated Gate Valves, designed for efficient flow, readily accommodate sand and pebbles, ensuring unobstructed operation. The valves uniquely incorporate a premium rubber compound that encapsulates any impurities during closure, which are then flushed out upon reopening. This process enables the rubber surface to revert to its original form, guaranteeing a leak-proof seal.

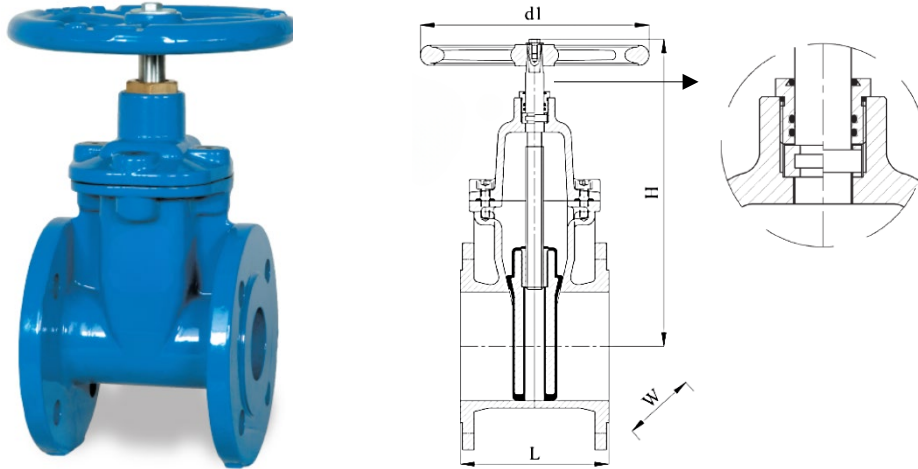

#### Application:

Gate Valves are used for isolation purposes and provide drip tight sealing once they are closed. When open, they provide undisturbed water flow. Gate Valves are not suitable for regulation purposes.

#### Features:

- **Efficient Operation:** Features a rolled stem design that ensures low operating torque values.
- **Accessory Availability:** Gearbox and Actuator accessories can be provided as per request.
- **Versatile Installations:** Ideal for above-ground or subterranean installations, complemented with accessories like handwheel, chainwheel, fixed and telescopic extension spindle, and surface box.
- **Customization:** Optional wedge guide is accessible for specific sizes upon request.



Phone  
+90 216 306 40 44



Email  
export@corvalve.net



Mobile/Whatsapp  
+90 542 306 40 43



Fax  
+90 216 306 40 44



Address  
Soğanlık Yeni Mah.  
Atatürk Cad.No:5/1  
Else Apt.Daire:9,34880  
Kartal/İstanbul

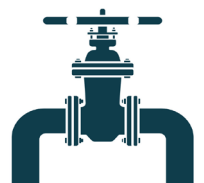

### Construction

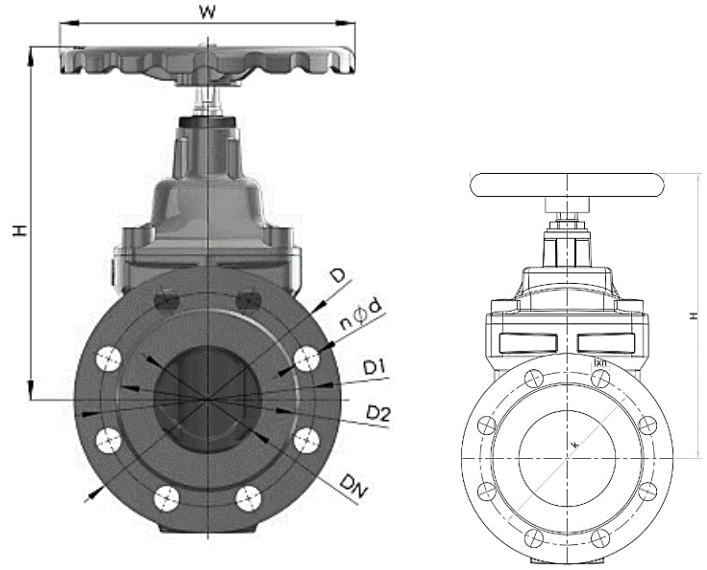
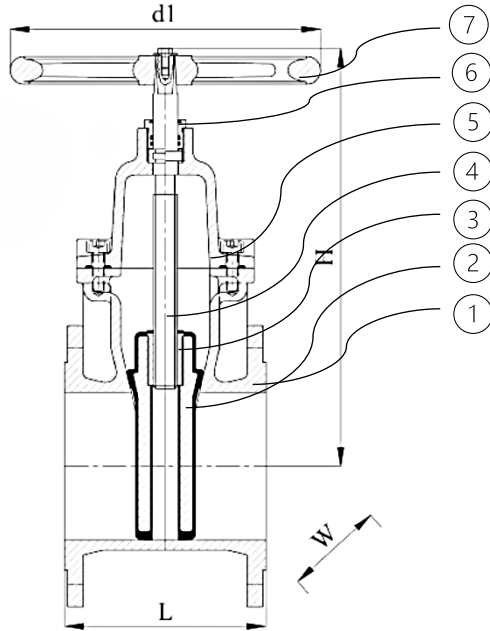

PART NO.	PART
1	Body
2	Wedge
3	Stem Nut
4	Stem
5	Bonnet
6	Gland
7	Handwheel

### Material Specification

Parts	Main Materials	Optional Materials
Body	Ductile Iron	Carbon Steel
Bonnet		Stainless Steel
Wedge		Nickle Aluminum Bronze
Stem	X20Cr13	SS 304, SS 316, NAB
Nuts	Bronze	Brass, SS304, SS 316, NAB
Rings	Bronze	Brass, SS304, SS 316, NAB
Seals	EPDM	NBR
Fasteners	8:8 (Galv.)	SS 304, SS 316
Handwheel	Cast Iron	Ductile Iron

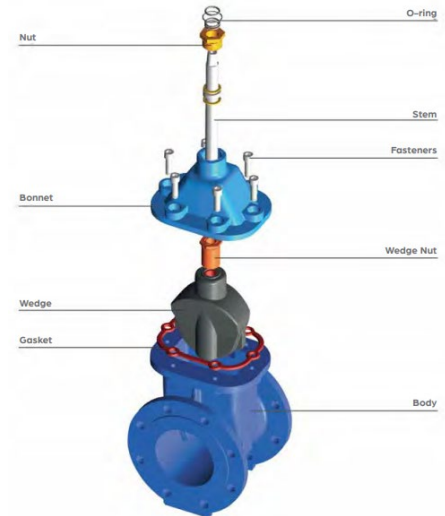

Phone  
+90 216 306 40 44



Email  
export@corvalve.net



Mobile/Whatsapp  
+90 542 306 40 43



Fax  
+90 216 306 40 44



Address  
Soğanlık Yeni Mah.  
Atatürk Cad.No:5/1  
Else Apt.Daire:9,34880  
Kartal/Istanbul



### Benefits of Resilient Seated Gate Valves

- **Space Efficiency:** Compact and lightweight design ensures easy handling and installation.
- **Effortless Operation:** Unique gate guide system offers low-torque operation for efficiency and ease of use.
- **Optimized Flow:** Full bore waterway design ensures maximum fluid flow.
- **Operational Flexibility:** Offers the choice of key or handwheel operation for enhanced operational adaptability.
- **Safe Maintenance:** Allows for stem seal replacement even while under pressure, minimizing downtime.
- **Directional Versatility:** Provides both Anti-Clockwise (ACC) and Clockwise (CC) closing mechanisms for better control.

### Pre-Installation:

1. **Pipeline Preparation:** Ensure the pipeline is thoroughly cleaned of all dirt, such as sand, dust, and welding residues.
2. **Tension Removal:** The pipeline should be tension-free before the start of the installation.
3. **Strainer Usage:** Install strainers at appropriate sections of the pipeline for future protection of the valve from dirt and foreign substances.
4. **Suitability Check:** Confirm that the valve meets the operating specifications of the medium such as maximum operating pressure and temperature, and its resistance to corrosiveness and abrasiveness.
5. **Clean Storage:** Store the valve in a clean environment and only remove the protective caps at the time of installation.
6. **Flange Measurement:** Verify that the distance between the flanges, where the valve will be connected, matches the length of the valve body.

### Installation:

1. **Gasket Installation:** Install suitable gaskets between the valve flanges and the counter flanges.
2. **Pressure Check:** Ensure that the fluid pressure does not exceed the nominal pressure indicated on the valve body.
3. **Valve Mounting:** Mount one side of the valve first, lightly fitting the bolts without fully tightening. Repeat the process for the other side of the valve. Lastly, uniformly tighten the bolts on both sides to avoid twisting the valve body.



Phone  
+90 216 306 40 44



Email  
export@corvalve.net



Mobile/Whatsapp  
+90 542 306 40 43



Fax  
+90 216 306 40 44



Address  
Soğanlık Yeni Mah.  
Atatürk Cad.No:5/1  
Else Apt.Daire:9,34880  
Kartal/Istanbul



#### Stem and Wedge Design:

The Gate Valve's stem is crafted from a single piece of stainless steel, featuring roll threading for smooth threads, ensuring low torque operation and minimal wear. The EPDM-vulcanized wedge undergoes rigorous inspection for Compression Set and Bonding Testing in accordance with EN 681-1. With optional wedge guides, the valve guarantees even lower torque values.

#### Coating Options:

Both thermoset and thermoplastic coatings are available, with an optional UV protection coating upon request. Coating standards can reach up to C5-I High (H, more than 15 years) as per EN ISO 12944-1. Coating quality is confirmed through sophisticated testing procedures, including Dew Point, Blast Surface Roughness, Particle Measurement, Coat Thickness, and more.

#### Certifications and Testing:

Our Resilient Seated Gate Valves hold WRAS approval for potable water applications and conformity to EN 1171. With our in-house hydraulic laboratory, we conduct comprehensive tests as outlined in EN 1074-2, including cycle, bending, and torque testing. Customer demonstrations are available upon request.

#### Functionality and Operation:

Our Gate Valves feature a revolving, non-rising, rolled, mono-block stem that transmits handwheel rotation to the wedge. With the bonnet nut holding the stem firm against axial movement, and the rubber-vulcanized wedge guided in a precast groove, the valve ensures undisturbed water flow when fully open, and a drip-tight seal when closed.

#### Notes:

1. Different flange drillings are available, including ISO, EN, ANSI, and others.
2. The standard operating temperature range is -10°C to +80°C.
3. All RAL Colors are available.
4. Potable water certified coating is available.
5. Both thermoset and thermoplastic coatings are available.



Phone  
+90 216 306 40 44



Email  
export@corvalve.net



Mobile/Whatsapp  
+90 542 306 40 43



Fax  
+90 216 306 40 44



Address  
Soğanlık Yeni Mah.  
Atatürk Cad.No:6/1  
Else Apt.Daire:9,34880  
Kartal/Istanbul



# CORVALVE

## GATE VALVES

EN 558-1 SERIES 14 (DIN 3202 - F4) RESILIENT SEATED

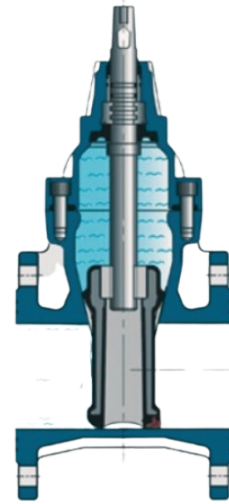
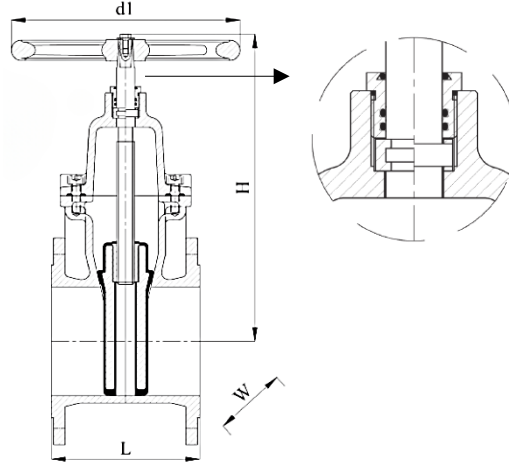

### DIMENSIONS (mm)

DN	40	50	65	80	100	125	150	200	250	300	350	400	450	500	600
D1	200	200	200	200	250	250	315	315	315	500	500	500	500	500	500
Height	225	230	255	285	325	375	425	520	590	665	744	980	1115	1190	1340
Width	200	200	200	200	250	250	315	315	375	460	520	583	680	756	886
Length	140	150	170	180	190	200	210	230	250	270	290	310	330	350	390
Weight (kg)	9	10	15	17	25	34	45	76	100	135	150	247	350	495	665



Phone  
+90 216 306 40 44



Email  
export@corvalve.net



Mobile/Whatsapp  
+90 542 306 40 43



Fax  
+90 216 306 40 44



Address  
Soğanlık Yeni Mah.  
Atatürk Cad.No:6/1  
Else Apt.Daire:9,34880  
Kartal/İstanbul

