

Description: The Metal Seated Gate Valves are purposefully engineered to provide effective flow isolation in pipeline systems. Their design incorporates sealing surfaces that facilitate regular cleaning of the valve seats by the fluid medium, ensuring consistent and reliable performance. With their dependable construction and functionality, these valves are a practical choice for industries seeking efficient flow control solutions.

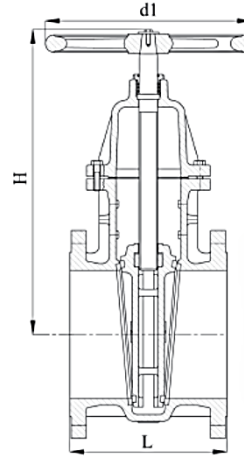

Application:

Gate Valves are used for isolation purposes and provide drip tight sealing once they are closed. When open, they provide undisturbed water flow. Gate Valves are not suitable for regulation purposes.

Features:

- **Smooth Operation:** Rolled stem design for low operating torque.
- **Ring Alternatives:** Options for pressed in, threaded, or welded rings.
- **Accessory Availability:** Gearbox and actuator accessories can be provided upon request.
- **Installation Flexibility:** Suitable for both above-ground and underground installations, supplemented by handwheel, chainwheel, fixed, and telescopic extension spindle, and surface box accessories.
- **Optional Extras:** Upon request, a wedge guide, jacking screw, wedge stop, or drain plug can be made available for specific sizes.
- **Additional Option for Large Sizes:** A bypass valve can be requested for larger sizes.



Phone
+90 216 306 40 44



Email
export@corvalve.net



Mobile/Whatsapp
+90 542 306 40 43



Fax
+90 216 306 40 44



Address
Soğanlık Yeni Mah.
Atatürk Cad.No:5/1
Else Apt.Daire:9,34880
Kartal/İstanbul

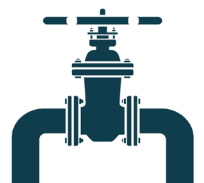

Construction

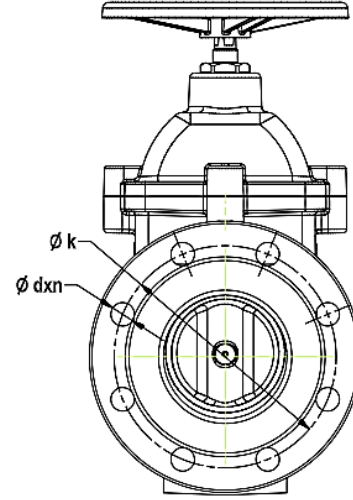
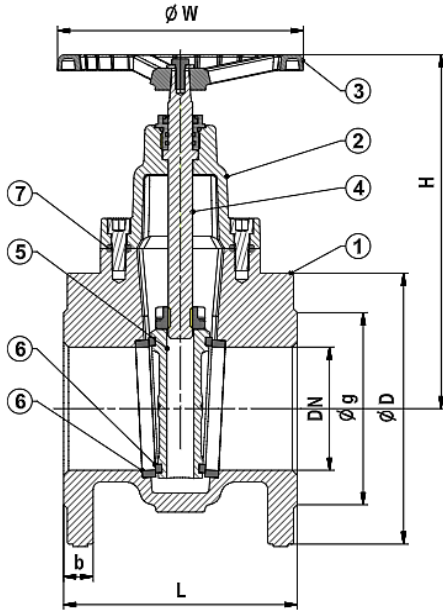

PART NO.	PART
----------	------

1	Body
2	Bonnet
3	Handwheel
4	Stem
5	Wedge
6	Seats
7	Gasket

Material Specification

Parts	Main Materials	Optional Materials
Body	Ductile Iron	Carbon Steel
Bonnet		Stainless Steel
Wedge		Nickle Aluminum Bronze
Stem	X20Cr13	SS 304, SS 316, NAB
Nuts	Bronze	Brass, SS304, SS 316, NAB
Rings	Bronze	Brass, SS304, SS 316, NAB
Seals	EPDM	NBR
Fasteners	8:8 (Galv.)	SS 304, SS 316
Handwheel	Cast Iron	Ductile Iron

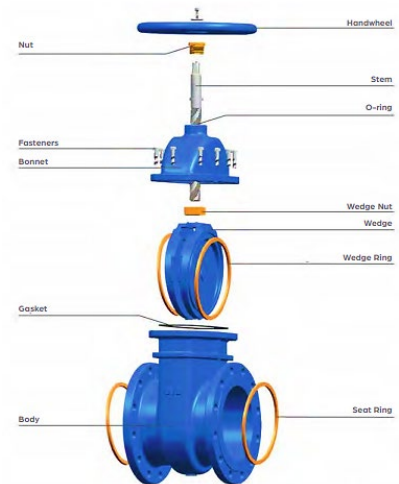

Phone
+90 216 306 40 44



Email
export@corvalve.net



Mobile/Whatsapp
+90 542 306 40 43



Fax
+90 216 306 40 44



Address
Soğanlık Yeni Mah.
Atatürk Cad.No:5/1
Else Apt.Daire:9,34880
Kartal/İstanbul

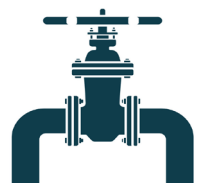

Benefits of Metal Seated Gate Valves

- **Exceptional Durability:** These valves can withstand high temperatures up to 400°C and high pressures ranging from 2500 to 5000psi.
- **Superior Sealing:** The valve uses a robust metal-on-metal seal which enhances the sealing effect and extends the valve's lifespan.
- **Corrosion Resilient:** Composed of corrosion-resistant materials like stainless steel, the valves perform well in harsh conditions, including exposure to strong acids, strong alkalis, and high salt concentrations.
- **Versatility:** The advanced sealing mechanisms of these valves allow them to handle high-viscosity substances and media containing particles or residues, reducing the risk of blockage.

Pre-Installation:

1. **Transportation and Handling:** Safeguard valves during transport and handling. Use flange holes, lifting eyes, or straps for lifting.
2. **Inspection:** Prior to installation, visually inspect the stem, valve seat area, flanges, and coating. Rectify or replace if any defects are found.

Operating Principles:

The valve's operation is handled by a stainless steel stem and a ductile iron wedge, which contains bronze rings. The gate valve is controlled through a rotating motion of the stem, either clockwise (to close) or anticlockwise (also to close). When the stem is manipulated, the wedge accordingly adjusts its position up or down along the stem's threaded section.

Installation:

1. **Connection Type:** Apply proper craftsmanship for the installation, following customer-specific pipeline connections (flanges, sockets, or spigot pipes).
2. **Flanged Valves:** Use appropriate gaskets, bolts, washers, and nuts for flanged valves. Bolts should be tightened in a crisscross pattern, following the gasket manufacturer's torque guidelines. Align valve flanges for even gasket pressure.
3. **Pipeline Alignment:** Make sure the connecting pipeline flanges align with the gate valve, tightened in a cross pattern to avoid tension loads on the valve body.
4. **Socket Valves:** Install socket valves as per pipe manufacturer's recommendations. Ensure pipe and valve socket diameters match, and gaskets are correctly positioned and lubricated.



Phone
+90 216 306 40 44



Email
export@corvalve.net



Mobile/Whatsapp
+90 542 306 40 43



Fax
+90 216 306 40 44



Address
Soğanlık Yeni Mah.
Atatürk Cad.No:5/1
Else Apt.Daire:9,34880
Kartal/İstanbul

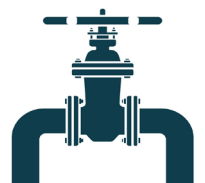

Versatility of Corvalve's Gate Valves:

Valves initiated its operations with the production of Metal Seated Gate Valves. This tried-and-tested design has been utilized in diverse applications worldwide including potable water distribution, shipping industry, HVAC systems, fire protection, industrial cooling, seawater intake, and main transmission lines. Due to their suitability for high pressure and large-scale applications, Metal Seated Gate Valves remain a top choice for professionals. They can accommodate up to PN63 in F5 face-to-face design and up to DN1200 in both F5 and BS face-to-face designs.

Customization and Precision in Design:

Metal Seated Gate Valves feature two body rings and two wedge rings, ensuring leak-free sealing. The matching of body and wedge rings facilitates sealing, though the metal-to-metal seal necessitates high expertise and superior production quality. Our proficiency in providing this leak-free seal hinges on the excellence of design, materials, machining, and ring installation in the valve body. Depending on size, pressure rating, and application, the rings can be installed on the body through press-fitting, threading, or welding. Additionally, we offer a range of ring materials such as brass, bronze, nickel aluminum bronze, and stainless steel 304, 316, to cater to diverse needs.

Mechanism of Gate Valve Operation:

The Gate Valves incorporate a rotating, non-rising, rolled, mono-block stem that conveys the handwheel's rotation to the wedge. The stem, rotating within the bonnet nut, links to the wedge via the wedge nut. The bonnet nut, threaded to the bonnet, secures the stem against axial movement. The wedge moves in a precast groove in the body, allowing unimpeded water flow when fully open. Both the body and the wedge possess pressed-in, threaded, or welded sealing seats to ensure leak-free sealing when the valve is closed.

Notes:

1. Different flange drillings are available, including ISO, EN, ANSI, and others.
2. The standard operating temperature range is -10°C to +80°C.
3. All RAL Colors are available.
4. Potable water certified coating is available.
5. Both thermoset and thermoplastic coatings are available.



Phone
+90 216 306 40 44



Email
export@corvalve.net



Mobile/Whatsapp
+90 542 306 40 43



Fax
+90 216 306 40 44



Address
Soğanlık Yeni Mah.
Atatürk Cad.No:6/1
Else Apt.Daire:9,34880
Kartal/Istanbul

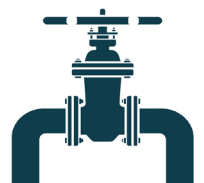

CORVALVE

GATE VALVES

EN 558-1 SERIES 14 (DIN 3202 - F4) METAL SEATED

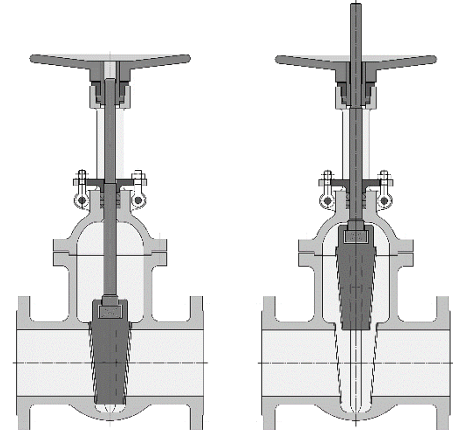
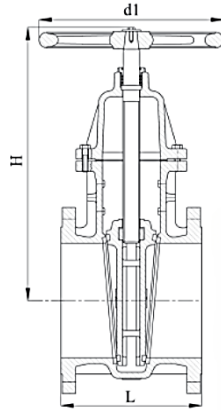

DIMENSIONS (mm)

DN	40	50	65	80	100	125	150	200	250	300	350	400	450	500	600
D1	160	160	160	200	250	250	315	315	315	400	400	500	500	500	500
Height	250	255	270	280	295	385	430	510	570	655	875	985	1065	1145	1340
Width	160	165	185	200	220	250	285	340	416	470	560	616	670	730	850
Length	140	150	170	180	190	200	210	230	250	270	290	310	330	350	390
Weight (kg)	12	12	16	21	24	35	49	83	117	157	250	315	450	455	700



Phone
+90 216 306 40 44



Email
export@corvalve.net



Mobile/Whatsapp
+90 542 306 40 43



Fax
+90 216 306 40 44



Address
Soğanlık Yeni Mah.
Atatürk Cad.No:5/1
Else Apt.Daire:9,34880
Kartal/İstanbul

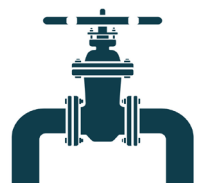

Description: The Metal Seated Gate Valves are purposefully engineered to provide effective flow isolation in pipeline systems. Their design incorporates sealing surfaces that facilitate regular cleaning of the valve seats by the fluid medium, ensuring consistent and reliable performance. With their dependable construction and functionality, these valves are a practical choice for industries seeking efficient flow control solutions.

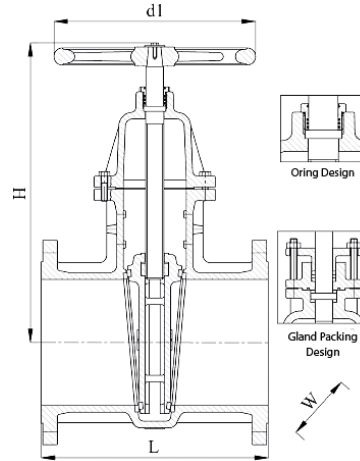

Application:

Gate Valves are used for isolation purposes and provide drip tight sealing once they are closed. When open, they provide undisturbed water flow. Gate Valves are not suitable for regulation purposes.

Features:

- **Efficient Operation:** The use of a rolled stem design results in lower operating torque values, enhancing ease of operation.
- **Versatile Ring Options:** Customers have the flexibility to choose from pressed-in, threaded, or welded rings, depending on their specific needs.
- **Accessories Availability:** Gearbox and actuator accessories can be provided as per customer requirements, adding to the adaptability of the product.
- **Adaptable Installations:** The valves are engineered to be compatible with both above-ground and underground installations, employing handwheels, chainwheels, fixed and telescopic extension spindles, along with surface box accessories.
- **Customizable Features:** Upon request, a wedge guide can be added for specific valve sizes to enhance operational precision.
- **Additional Options:** For tailored requirements, optional elements like a jacking screw, wedge stop, or drain plug can be provided for particular valve sizes.
- **Bypass Valve Option:** For larger valve sizes, an optional bypass valve can be made available upon request, boosting the functionality and versatility of the gate valve.



Phone
+90 216 306 40 44



Email
export@corvalve.net



Mobile/Whatsapp
+90 542 306 40 43



Fax
+90 216 306 40 44



Address
Soğanlık Yeni Mah.
Atatürk Cad.No:5/1
Else Apt.Daire:9,34880
Kartal/İstanbul

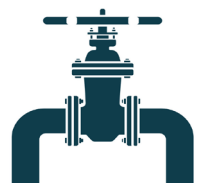

Construction

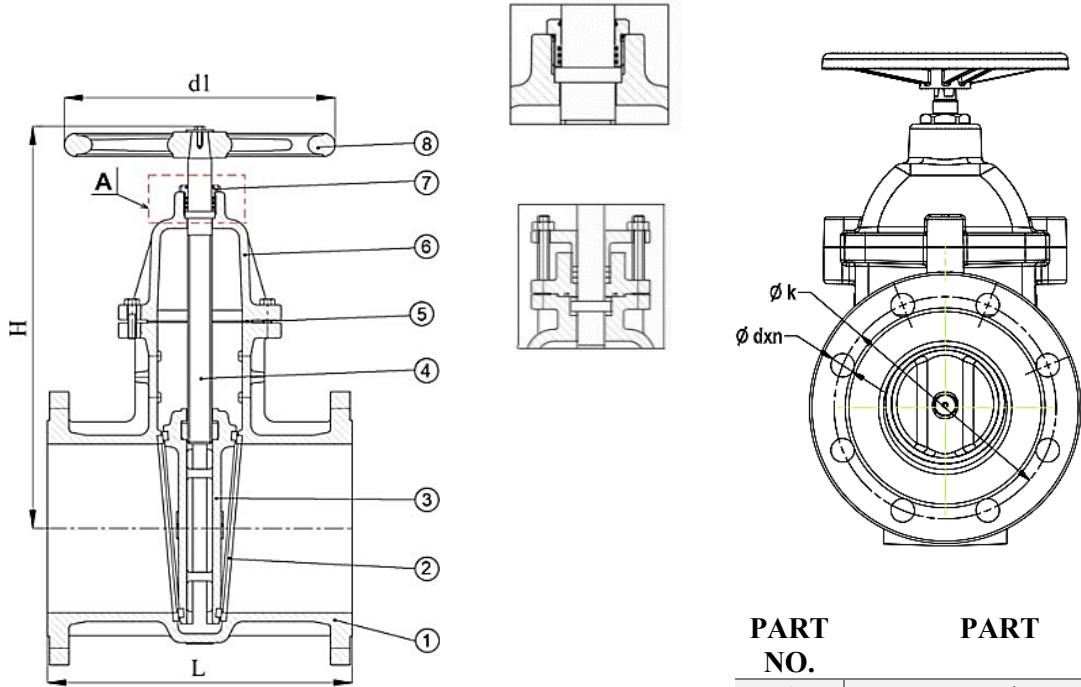

PART NO.	PART
1	Body
2	Seat
3	Wedge
4	Stem
5	Gasket
6	Bonnet
7	Bonnet Nut
8	Handwheel

Material Specification

Parts	Main Materials	Optional Materials
Body	Ductile Iron	Carbon Steel
Bonnet		Stainless Steel
Wedge		Nickle Aluminum Bronze
Stem	X20Cr13	SS 304, SS 316, NAB
Nuts	Bronze	Brass, SS304, SS 316, NAB
Rings	Bronze	Brass, SS304, SS 316, NAB
Seals	EPDM	NBR
Fasteners	8:8 (Galv.)	SS 304, SS 316
Handwheel	Cast Iron	Ductile Iron

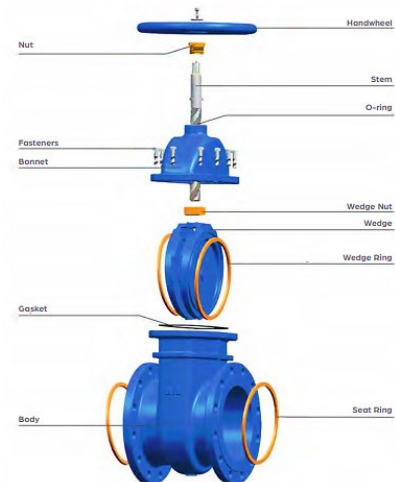

Phone
+90 216 306 40 44



Email
export@corvalve.net



Mobile/Whatsapp
+90 542 306 40 43



Fax
+90 216 306 40 44



Address
Soğanlık Yeni Mah.
Atatürk Cad.No:5/1
Else Apt.Daire:9,34880
Kartal/İstanbul



Benefits of Metal Seated Gate Valves

- **Exceptional Durability:** These valves can withstand high temperatures up to 400°C and high pressures ranging from 2500 to 5000psi.
- **Superior Sealing:** The valve uses a robust metal-on-metal seal which enhances the sealing effect and extends the valve's lifespan.
- **Corrosion Resilient:** Composed of corrosion-resistant materials like stainless steel, the valves perform well in harsh conditions, including exposure to strong acids, strong alkalis, and high salt concentrations.
- **Versatility:** The advanced sealing mechanisms of these valves allow them to handle high-viscosity substances and media containing particles or residues, reducing the risk of blockage.

Pre-Installation:

1. **Transportation and Handling:** Safeguard valves during transport and handling. Use flange holes, lifting eyes, or straps for lifting.
2. **Inspection:** Prior to installation, visually inspect the stem, valve seat area, flanges, and coating. Rectify or replace if any defects are found.

Operating Principles:

The valve's operation is handled by a stainless steel stem and a ductile iron wedge, which contains bronze rings. The gate valve is controlled through a rotating motion of the stem, either clockwise (to close) or anticlockwise (also to close). When the stem is manipulated, the wedge accordingly adjusts its position up or down along the stem's threaded section.

Installation:

1. **Connection Type:** Apply proper craftsmanship for the installation, following customer-specific pipeline connections (flanges, sockets, or spigot pipes).
2. **Flanged Valves:** Use appropriate gaskets, bolts, washers, and nuts for flanged valves. Bolts should be tightened in a crisscross pattern, following the gasket manufacturer's torque guidelines. Align valve flanges for even gasket pressure.
3. **Pipeline Alignment:** Make sure the connecting pipeline flanges align with the gate valve, tightened in a cross pattern to avoid tension loads on the valve body.
4. **Socket Valves:** Install socket valves as per pipe manufacturer's recommendations. Ensure pipe and valve socket diameters match, and gaskets are correctly positioned and lubricated.



Phone
+90 216 306 40 44



Email
export@corvalve.net



Mobile/Whatsapp
+90 542 306 40 43



Fax
+90 216 306 40 44



Address
Soğanlık Yeni Mah.
Atatürk Cad.No:5/1
Else Apt.Daire:9,34880
Kartal/İstanbul

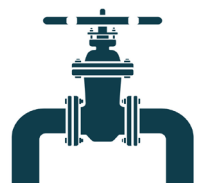

Inception and Applications of Corvalve Valves:

Corvalve started with Metal Seated Gate Valves production, earning worldwide usage in systems like water distribution, HVAC, fire protection, industrial cooling, and more. Their high pressure and large size adaptability make them a professionals' choice, catering to up to PN63 in F5 design and DN1200 in F5 & BS design. They're reliable for critical isolation tasks.

Design Versatility of Corvalve Valves:

Metal Seated Gate Valves feature two body and wedge rings ensuring leak-proof sealing. Achieving this metal-to-metal seal requires expertise and quality. Ring installation methods—press-fitting, threading, or welding—depend on valve size, pressure rating, and application. Rings can be of brass, bronze, nickel aluminum bronze, stainless steel 304, 316 per request.

Operational Dynamics of Corvalve Valves:

The valves utilize a rotating, non-rising, rolled, mono-block stem, transmitting handwheel rotation to the wedge. The bonnet nut holds the stem against axial movement. The wedge, guided in a precast groove, provides uninterrupted water flow when fully open. Both body and wedge have sealing seats ensuring leak-proof sealing when closed.

Notes:

1. Different flange drillings are available, including ISO, EN, ANSI, and others.
2. The standard operating temperature range is -10°C to +80°C.
3. All RAL Colors are available.
4. Potable water certified coating is available.
5. Both thermoset and thermoplastic coatings are available.



Phone
+90 216 306 40 44



Email
export@corvalve.net



Mobile/Whatsapp
+90 542 306 40 43



Fax
+90 216 306 40 44



Address
Soğanlık Yeni Mah.
Atatürk Cad.No:6/1
Else Apt.Daire:9,34880
Kartal/İstanbul



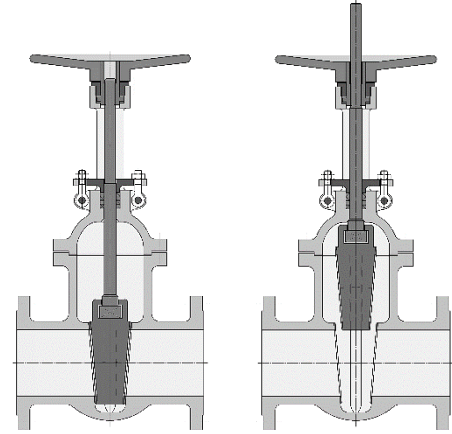
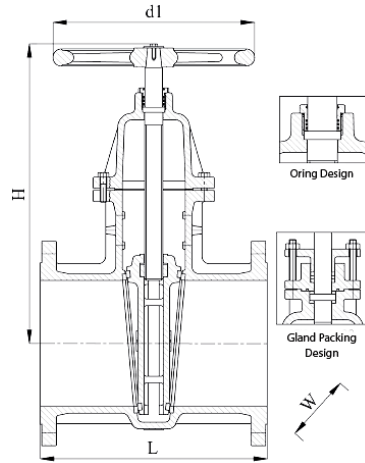

DIMENSIONS (mm)

DN	40	50	65	80	100	125	150	200	250	300	350	400	450	500	600	700	800	900	1000	1200
D1	200	200	250	250	250	315	315	315	400	400	500	600	800	800	800	800	800	800	900	1000
Height	235	240	265	290	330	390	430	535	590	700	865	970	1075	1190	1365	1530	1690	1925	2007	2305
Width	200	200	250	250	250	315	315	400	410	505	565	640	770	800	895	1050	1126	1500	1255	1485
Length	240	250	270	280	300	325	350	400	450	500	550	600	650	700	800	900	1000	1100	1200	1400
Weight (kg)	15	15	21	27	31	51	62	100	155	221	324	440	575	760	1180	1600	2337	2500	3200	5280



Phone
+90 216 306 40 44



Email
export@corvalve.net



Mobile/Whatsapp
+90 542 306 40 43



Fax
+90 216 306 40 44



Address
Soğanlık Yeni Mah.
Atatürk Cad.No:6/1
Else Apt.Daire:9,34880
Kartal/İstanbul

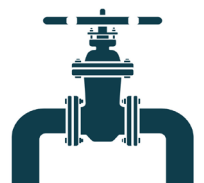

Description: The Metal Seated Gate Valves are purposefully engineered to provide effective flow isolation in pipeline systems. Their design incorporates sealing surfaces that facilitate regular cleaning of the valve seats by the fluid medium, ensuring consistent and reliable performance. With their dependable construction and functionality, these valves are a practical choice for industries seeking efficient flow control solutions.

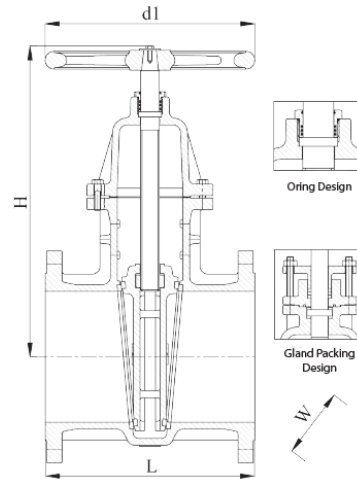

Application:

Gate Valves are used for isolation purposes and provide drip tight sealing once they are closed. When open, they provide undisturbed water flow. Gate Valves are not suitable for regulation purposes.

Features:

- **Smooth Operation:** Rolled stem design for low operating torque.
- **Ring Alternatives:** Options for pressed in, threaded, or welded rings.
- **Accessory Availability:** Gearbox and actuator accessories can be provided upon request.
- **Installation Flexibility:** Suitable for both above-ground and underground installations, supplemented by handwheel, chainwheel, fixed, and telescopic extension spindle, and surface box accessories.
- **Optional Extras:** Upon request, a wedge guide, jacking screw, wedge stop, or drain plug can be made available for specific sizes.
- **Additional Option for Large Sizes:** A bypass valve can be requested for larger sizes.



Phone
+90 216 306 40 44



Email
export@corvalve.net



Mobile/Whatsapp
+90 542 306 40 43



Fax
+90 216 306 40 44



Address
Soğanlık Yeni Mah.
Atatürk Cad.No:5/1
Else Apt.Daire:9,34880
Kartal/Istanbul



Construction

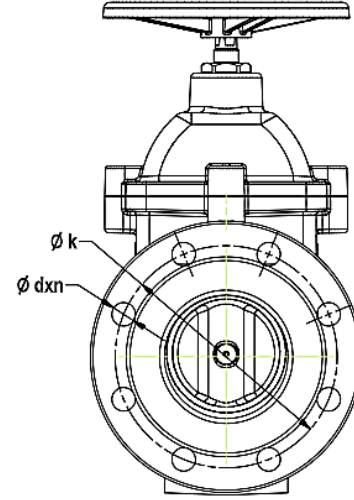
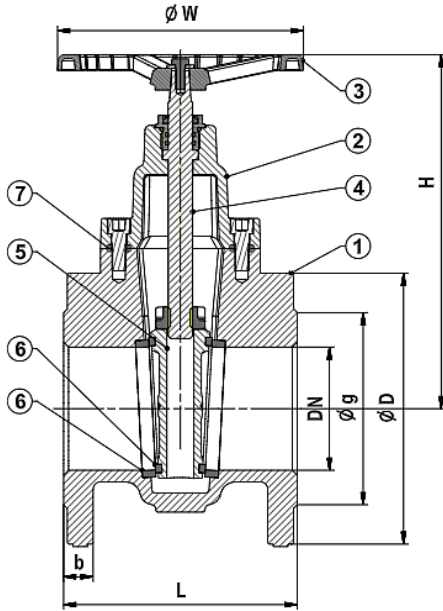

PART NO.	PART
----------	------

1	Body
2	Bonnet
3	Handwheel
4	Stem
5	Wedge
6	Seats
7	Gasket

Material Specification

Parts	Main Materials	Optional Materials
Body	Ductile Iron	Carbon Steel
Bonnet		Stainless Steel
Wedge		Nickle Aluminum Bronze
Stem	X20Cr13	SS 304, SS 316, NAB
Nuts	Bronze	Brass, SS304, SS 316, NAB
Rings	Bronze	Brass, SS304, SS 316, NAB
Seals	EPDM	NBR
Fasteners	8:8 (Galv.)	SS 304, SS 316
Handwheel	Cast Iron	Ductile Iron

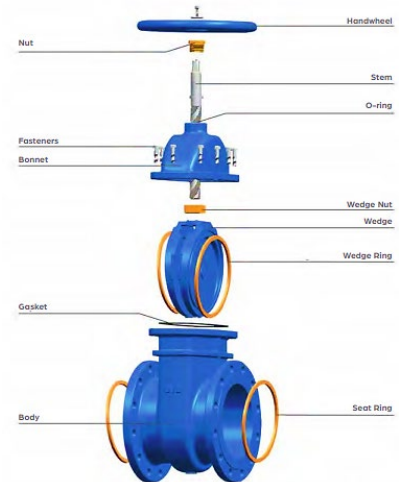

Phone
+90 216 306 40 44



Email
export@corvalve.net



Mobile/Whatsapp
+90 542 306 40 43



Fax
+90 216 306 40 44



Address
Soğanlık Yeni Mah.
Atatürk Cad.No:5/1
Else Apt.Daire:9,34880
Kartal/İstanbul



Benefits of Metal Seated Gate Valves

- **Exceptional Durability:** These valves can withstand high temperatures up to 400°C and high pressures ranging from 2500 to 5000psi.
- **Superior Sealing:** The valve uses a robust metal-on-metal seal which enhances the sealing effect and extends the valve's lifespan.
- **Corrosion Resilient:** Composed of corrosion-resistant materials like stainless steel, the valves perform well in harsh conditions, including exposure to strong acids, strong alkalis, and high salt concentrations.
- **Versatility:** The advanced sealing mechanisms of these valves allow them to handle high-viscosity substances and media containing particles or residues, reducing the risk of blockage.

Pre-Installation:

1. **Transportation and Handling:** Safeguard valves during transport and handling. Use flange holes, lifting eyes, or straps for lifting.
2. **Inspection:** Prior to installation, visually inspect the stem, valve seat area, flanges, and coating. Rectify or replace if any defects are found.

Operating Principles:

The valve's operation is handled by a stainless steel stem and a ductile iron wedge, which contains bronze rings. The gate valve is controlled through a rotating motion of the stem, either clockwise (to close) or anticlockwise (also to close). When the stem is manipulated, the wedge accordingly adjusts its position up or down along the stem's threaded section.

Installation:

1. **Connection Type:** Apply proper craftsmanship for the installation, following customer-specific pipeline connections (flanges, sockets, or spigot pipes).
2. **Flanged Valves:** Use appropriate gaskets, bolts, washers, and nuts for flanged valves. Bolts should be tightened in a crisscross pattern, following the gasket manufacturer's torque guidelines. Align valve flanges for even gasket pressure.
3. **Pipeline Alignment:** Make sure the connecting pipeline flanges align with the gate valve, tightened in a cross pattern to avoid tension loads on the valve body.
4. **Socket Valves:** Install socket valves as per pipe manufacturer's recommendations. Ensure pipe and valve socket diameters match, and gaskets are correctly positioned and lubricated.



Phone
+90 216 306 40 44



Email
export@corvalve.net



Mobile/Whatsapp
+90 542 306 40 43



Fax
+90 216 306 40 44



Address
Soğanlık Yeni Mah.
Atatürk Cad.No:5/1
Else Apt.Daire:9,34880
Kartal/Istanbul



Gate Valve Evolution and Applications:

Starting with Metal Seated Gate Valves, Corvalve earned trust worldwide in fields like water systems, shipping, HVAC, fire safety, and more. These valves, particularly ideal for high-pressure and large-scale applications, support up to PN63 in F5 design and DN1200 in F5 & BS designs, serving as reliable isolation tools.

Design and Customizability of Gate Valves:

Corvalve's Metal Seated Gate Valves feature two body and wedge rings, offering a leak-proof seal. The metal-to-metal sealing, achieved through exceptional design, material, machining, and ring installation, can be customized with varied ring materials like brass, bronze, nickel aluminum bronze, or stainless steel 304, 316.

Gate Valve Operation and Structure:

Corvalve's Gate Valves use a rotating, non-rising, rolled, mono-block stem to transfer handwheel rotation to the wedge. With the wedge guided in a precast body groove, it allows smooth water flow when fully open and ensures a leak-proof closure through sealing seats on both body and wedge.

Notes:

1. Different flange drillings are available, including ISO, EN, ANSI, and others.
2. The standard operating temperature range is -10°C to +80°C.
3. All RAL Colors are available.
4. Potable water certified coating is available.
5. Both thermoset and thermoplastic coatings are available.



Phone
+90 216 306 40 44



Email
export@corvalve.net



Mobile/Whatsapp
+90 542 306 40 43



Fax
+90 216 306 40 44



Address
Soğanlık Yeni Mah.
Atatürk Cad.No:6/1
Else Apt.Daire:9,34880
Kartal/Istanbul

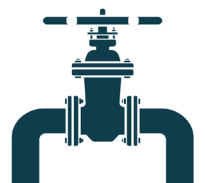

CORVALVE

GATE VALVES

EN 558-1 SERIES 3 (BS 5163) METAL SEATED

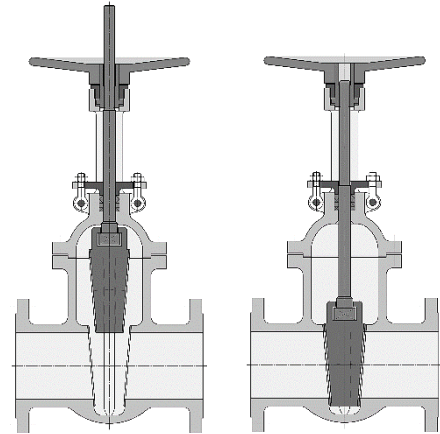
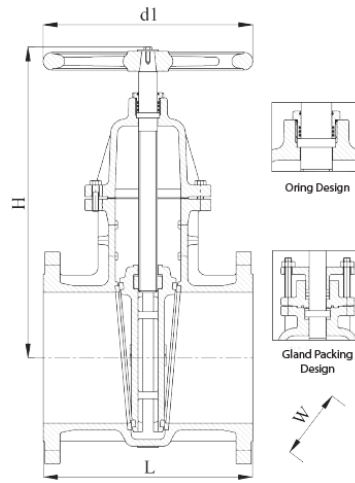

DIMENSIONS (mm)

DN	40	50	65	80	100	125	150	200	250	300	350	400	450	500	600	700	800	900	1000	1200
D1	200	200	250	250	250	315	315	315	400	400	500	600	600	800	800	800	800	800	900	1000
Height	235	240	265	290	330	390	430	535	590	700	865	970	1075	1145	1365	1530	1690	1925	2007	2303
Width	200	200	250	250	250	315	315	400	500	505	565	640	770	730	895	1050	1126	1500	1255	1485
Length	165	178	190	203	229	254	267	292	330	356	381	406	432	457	508	640	660	711	813	838
Weight (kg)	13	14	21	25	29	45	60	87	137	220	315	460	500	590	1100	1520	2180	2400	2633	4178



Phone
+90 216 306 40 44



Email
export@corvalve.net



Mobile/Whatsapp
+90 542 306 40 43



Fax
+90 216 306 40 44



Address
Soğanlık Yeni Mah.
Atatürk Cad.No:6/1
Elsen Apt.Daire:9,34880
Kartal/İstanbul

